



operational guide

# **MAX REPLY**



**bpost  
international**

# Index

## Types of returns

Maximum 50 g  
Maximum 250 g

## Return labels

### How to prepare your labels

Label specifications for countries  
where the authorised weight is  $\leq 50$  g  
Label specifications for countries  
where the authorised weight is  $\leq 250$  g  
Label specifications for postcards  
and aerograms

## Practical information

### Managing returns

3  
3  
3  
4  
4  
5  
6  
7  
8  
8

# Congratulations!

You have chosen bpost international to manage your returns with all the advantages that our Max Reply solution has to offer.

This Guide will provide step-by-step instructions for correctly preparing your international returns. bpost international will take care of the rest, making sure you are provided with efficient and reliable service.

# Types of returns

## Maximum 50 g

All types of printed returns, as long as:

- the maximum weight per return item does not exceed **50 g**;
- the minimum dimensions of the return item are: width  $\geq 90$  mm and length  $\geq 140$  mm;
- the maximum dimensions of the return item are: width + length + thickness  $\leq 900$  mm and length  $\leq 600$  mm.

**Countries covered:** worldwide.

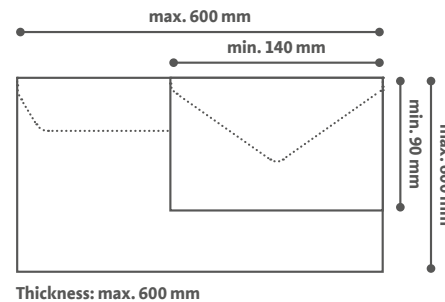

## Maximum 250 g

For some countries (in Europe mainly), the authorised weight for printed returns is up to 250 g, but the authorised dimensions vary:

- length: 140-381 mm;
- width: 90-305 mm;
- thickness:  $\leq 20$  mm.

**Countries covered:** please consult the list on our website [www.bpostinternational.com](http://www.bpostinternational.com) > Resources > Downloads > Country list > bpost international Max Reply.

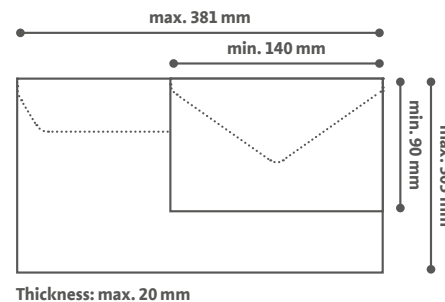

# Return labels

## How to prepare your labels

You simply include your reply card or your preprinted envelope with your item, direct mail or other marketing materials. It is then easy and convenient for your customers to post the return item from their country of origin in a post box or post office, as they would do for a letter.

**The front of the reply card or preprinted envelope must follow the layout below:**

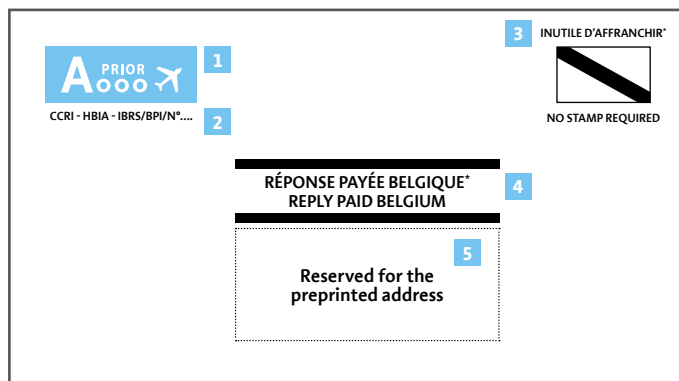

- 1 Pictogram: "A Prior" printed in blue or black.
- 2 The contract number we assigned to you for this service. This number always consists of four digits.
- 3 The words: " Inutile d'affranchir/ No stamp required\*".
- 4 The words: "Réponse payée Belgique/ Reply Paid Belgium\*".
- 5 The return address of our sorting centre together with your company name and P.O. Box number (or directly to your address for customers in Belgium).

\* Required in French, optional in English.

# Return labels

## How to prepare your labels

Label specifications for countries where the authorised weight is  $\leq 50$  g

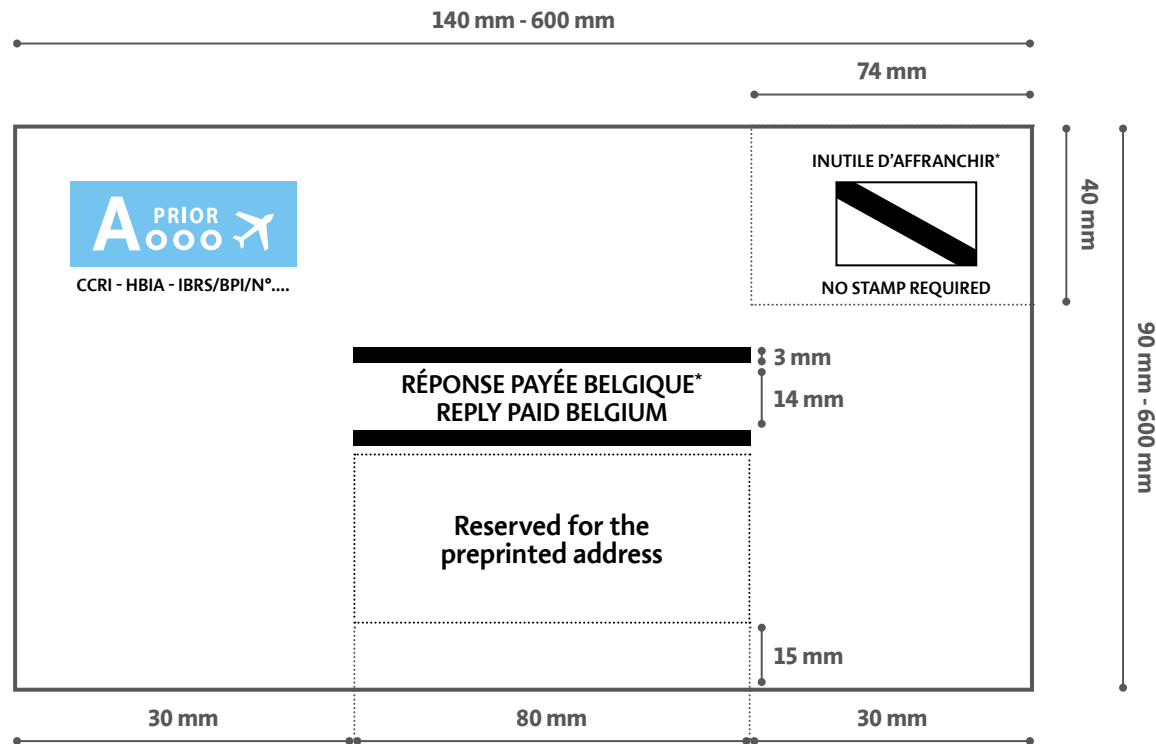

In addition, you must send us a PDF file of your return label for approval before use.

You can also create your label directly through our online application e-Shipper!

\* Required in French, optional in English.

# Return labels

## How to prepare your labels

Label specifications for countries where the authorised weight is  $\leq 250$  g

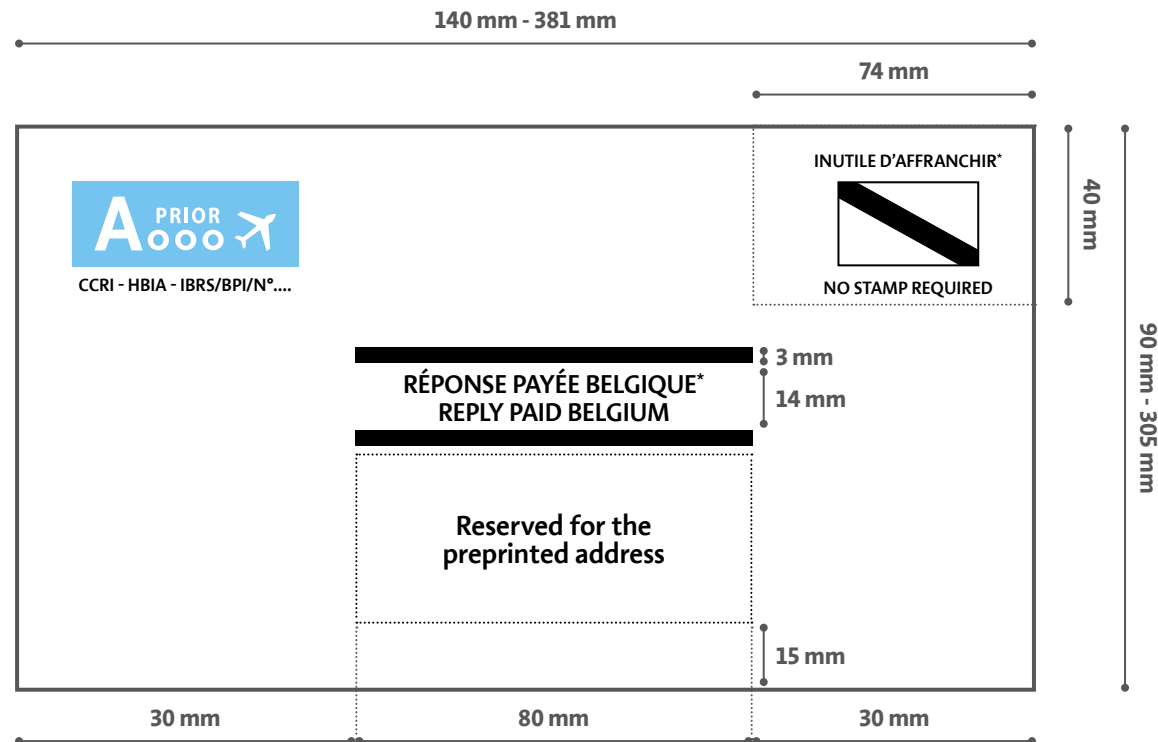

In addition, you must send us a PDF file of your return label for approval before use.

You can also create your label directly through our online application e-Shipper!

\* Required in French, optional in English.

# Return labels

## How to prepare your labels

### Label specifications for postcards and aerograms

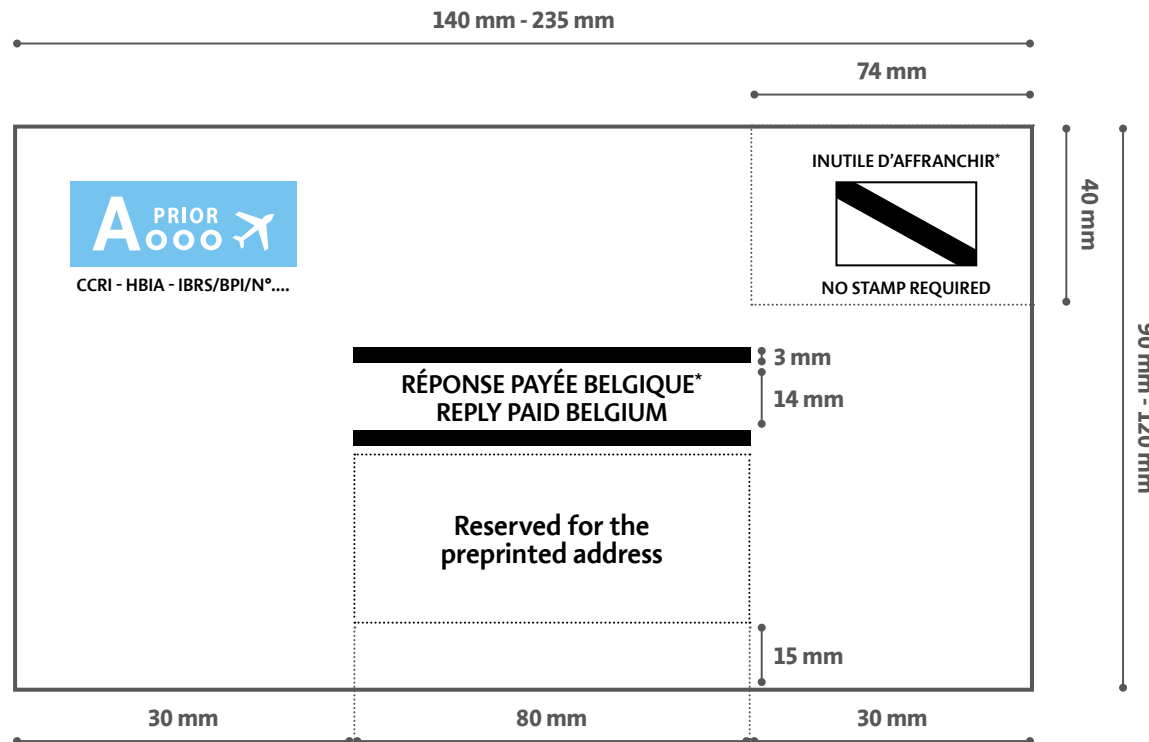

In addition, you must send us a PDF file of your return label for approval before use.

You can also create your label directly through our online application e-Shipper!

\* Required in French, optional in English.

# Practical information

## Managing returns

For Belgian customers: returns arrive directly at your address.

For non-Belgian customers: we group all your returns: according to the service you request, we send them to the address of your choice, on a daily, weekly, bi-monthly or monthly, etc.



### Be careful not to confuse "returns" with "undelivered items"!

- **"Returns"** refer to reply cards, preprinted envelopes, etc. that your addressees have actually received and to which they have replied.
- **"Undelivered items"** refer to pieces of mail that did not arrive at their destination because the address was incorrect, the person had moved, etc. and the items are being returned to sender as undeliverable.

## Sales Contact

 +32 2 276 22 74  +32 2 276 21 38  [sales.international@bpost.be](mailto:sales.international@bpost.be)  [www.bpostinternational.com](http://www.bpostinternational.com)